

LOADING INSTRUCTIONS :

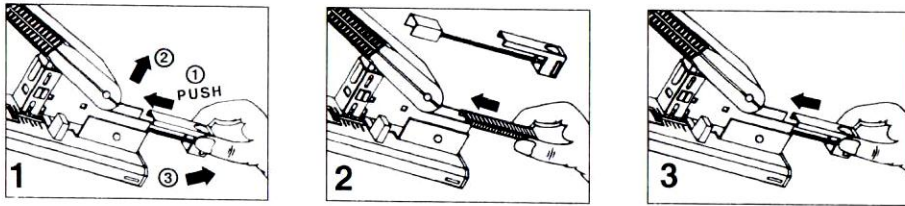

1. Remove pusher assembly by pushing forward and up, pull pusher assembly out.
2. Insert a full strip of Heavy Duty Staples.
3. Replace pusher assembly.

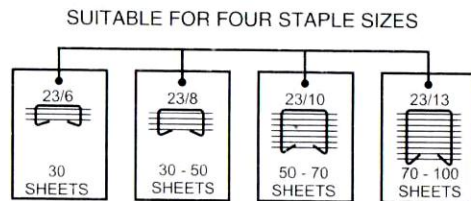

CAUTIONS :

1. Use proper staple pins for required stapling.
2. Avoid use without papers.

SPECIFICATIONS :

- Staples 4 sizes as mentioned above
- Staple loading capacity 100 staples
- Stapling capacity 30-100 quality paper sheets
- Throat depth 65 mm
- Size L 290 X W 65 X H 170 mm
- Weight 800 gms.

Spares available at nominal price.

DESK TOP HEAVY DUTY STAPLER

MAXIMUM WORK WITH MINIMUM EFFORT

HD-1213

INSTRUCTION MANUAL

STAPLES USED	LEG LENGTH	STAPLING CAPACITY (COPY PAPER)
1206 FA-H	6 mm	Upto 30 Sheets
1208 FA-H	8 mm	30-50 Sheets
1210 FA-H	10 mm	50-70 Sheets
1213 FA-H	13 mm	70-100 Sheets

UNIQUE JAM CLEARING MECHANISM
Which ensures problem free stapling



Viewing Slot to Identify
Staples Sizes

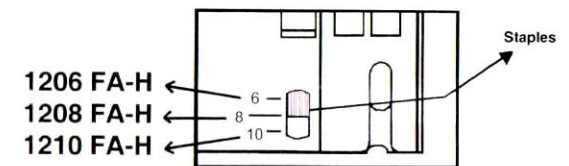

• ASSEMBLY DETAILS FOR HD-1213 STAPLER

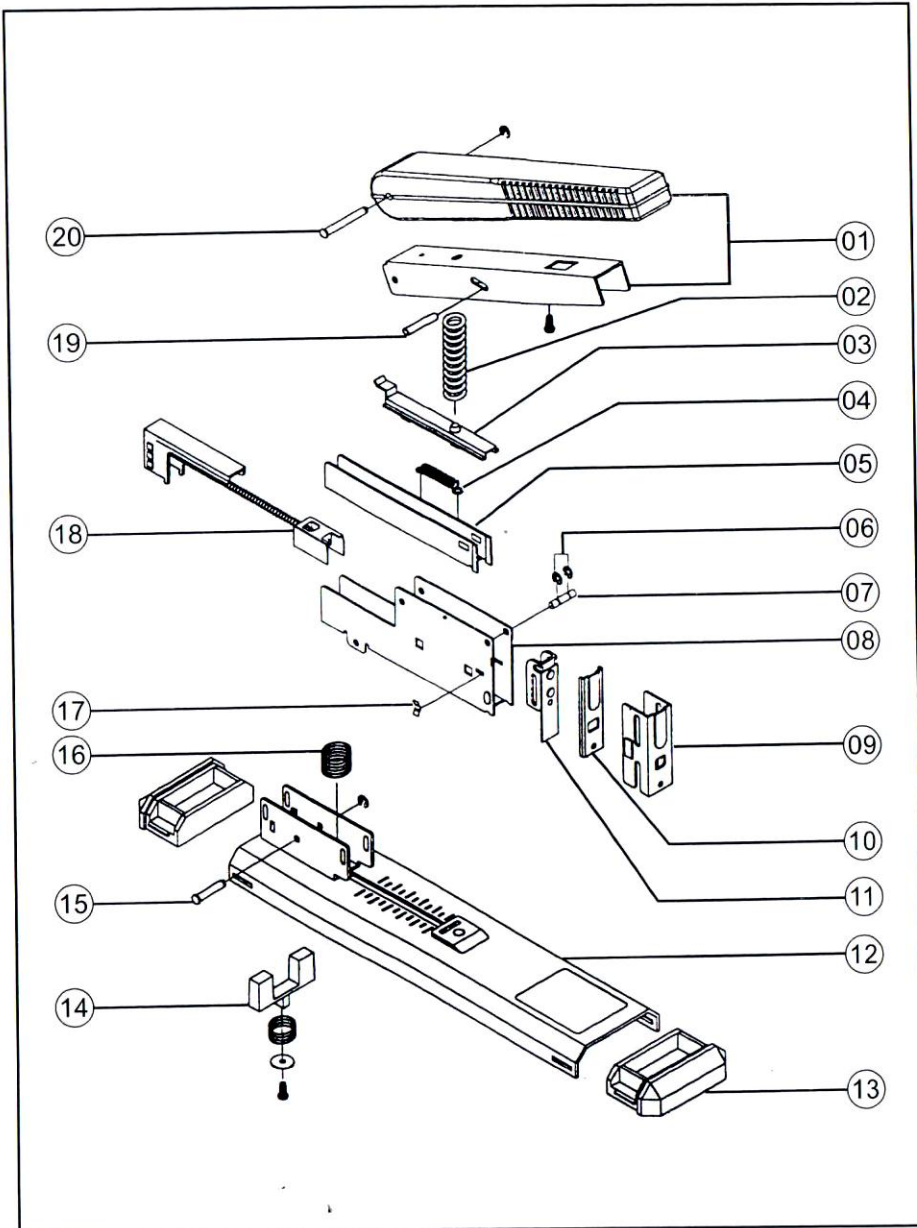

• ASSEMBLY DETAILS FOR HD-1213 STAPLER

S. NO.	DESCRIPTION OF PARTS	ORDER CODE
01	HANDLE ASSEMBLY	KP-1213-01
02	COMPRESSION SPRING	KP-1213-02
03	STAPLE COVER	KP-1213-03
04	TENSION SPRING	KP-1213-04
05	STAPLE GUIDE	KP-1213-05
06	CIRCLIP	KP-1213-06
07	PIN FOR PUNCH HOLDER	KP-1213-07
08	MAGAZINE	KP-1213-08
09	FRONT GUIDE	KP-1213-09
10	GUIDE FOR SPRING PUNCH	KP-1213-10
11	PUNCH ASSEMBLY	KP-1213-11
12	BASE ASSEMBLY	KP-1213-12
13	RUBBER PAD	KP-1213-13
14	PAPER STOPPER ASSEMBLY	KP-1213-14
15	MAIN HINGE PIN	KP-1213-15
16	LIFTING SPRING	KP-1213-16
17	GUIDE LOCK	KP-1213-17
18	PUSHER ASSEMBLY	KP-1213-18
19	STOPPER PIN	KP-1213-19
20	HANDLE HINGE PIN	KP-1213-20

★ ALL SPARES AVAILABLE ON REQUEST AT REASONABLE PRICE